

Automation box for HVAC (heating/ventilation/air conditioning) and Single room control applications

- Power and data over one cable, with 230V voltage outputs
- Connection manufacturer-independent Sensors/Actors via RS485 (Modbus RTU)
- Automatic or manual conversion to Modbus TCP signals, manufacturer-independent control selection (PLC/BMS)
- M12 5-pin pluggable connections, with 24V power supply and bus
- Slot for other bus protocols
- Bluetooth connection for app configuration
- Optional with CODESYS® PLC control application

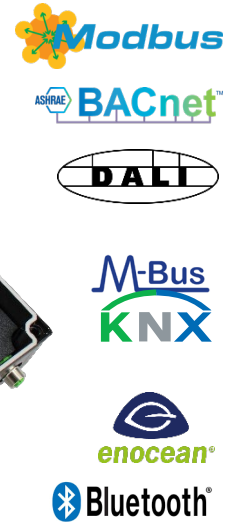

Savings on cable pull up to 80%

Power and communication in one cable

Modular, flexible and fast in installation and communication

Increase of the information content by up to 95%

Technical data

| | | |
|--------------------------|------------------------------------|--|
| General data | Name/Type | powerIO®-Box T1.B100 |
| | Item number | 100101 |
| | Color | Black |
| Electrical data | Nominal voltage | AC 230V |
| | Nominal voltage frequency | 50/60 Hz |
| | Power consumption during operation | 20 W |
| | Power consumption sleep mode | 10 W |
| | Power consumption dimensioning | 50 VA |
| | Connection power supply / control | powerIO®-Line cable Power 3 x 4.00 mm ² Data 2 x (2 x 0.34 mm ²) |
| | Output voltage, 24V power supply | 24V DC, max. 1,9A |
| Output voltage tolerance | ± 2,5 % | |
| Short circuit behaviour | | |
| Functional data | Control communicative TCP | Modbus TCP |
| | Control communicative Port 1 to 4 | Modbus RTU |
| CPU and memory | Processor | ARM Cortex A53 core, 1,2 GHz |
| | RAM memory | 1 Gbyte |
| | Flash memory | 4Gbyte eMMC |
| UPS function | buffer time for 5V power supply | Up to 30s, safe shut down |
| | Components with UPS function | CPU, Ethernetchip |
| Security | Protection class IEC/EN | IP 64 |
| | EMC | CE according to 2014/30/EU |
| | Ambient temperature | -30...50°C |
| | Storage temperature | -40...70°C |
| | Ambient Humidity | Max. 95% r.h., non-condensing |
| | Maintenance | Maintenance-free |
| | Dimensions | 255 x 266 x 64 mm (W x H x D) |
| | Weight | 1360 g |

Safety Instructions



- It is forbidden to install the **powerIO®** box in the immediate vicinity of frequency converters. Frequency converters must be wired with all protective measures to ensure that the required regulations and guidelines are observed (e.g. line filters etc.).
- The supply voltage must correspond to the specifications in the documentation
- The connection terminals inside the device may only be wired by authorized and instructed personnel.
- Do not carry out any wiring work under voltage. There is a risk of electric shock as some terminals may carry 230/400 V. The installation must be carried out by authorized personnel. The legal and official regulations must be observed.
- Avoid connecting and disconnecting plug connections (under voltage). This could destroy the devices!
- Make sure that no objects, e.g. screws, screen remnants, sleeves or other fastening material get into the device.
- This device is designed for use in stationary heating, ventilation and air conditioning systems. It is forbidden to use the device for applications outside the specified field of application, especially not in airplanes or any other means of transportation in the air.
- Avoid installation in places with extreme and rapid temperature changes. Please note that an outdoor application is only possible if no water, snow, ice, sunlight or aggressive gases directly affect the box and if it is guaranteed that the environmental conditions are always within the limits of the data sheet.

Product features

| | |
|---|--|
| System description | The powerIO® system combines power and data in only one cable and enables a decentralized design! Reduction of the building automation costs and cable pulling costs, reduction of the fire load in the building, reduction of the construction time, fewer planning interfaces and many more possibilities with high-quality information of the individual devices are only a few advantages of the powerIO® -System. |
| Installation | The powerIO® -Boxes are mounted decentrally in the immediate vicinity of the sensor and actuators. For example in heating circuits, directly at the ventilation unit or in rooms for individual room control. The powerIO® -Line then connects the boxes with each other. Power and communication are transmitted via the powerIO® -Line. |
| Connections from inside (remove cover) | <p>Power supply 230 V: 3 x 4.0 mm², incoming and outgoing.</p> <p>Ethernet: 2 x 2 x 0.34 mm², incoming and outgoing.</p> <p>230V outlets: 2 x 230 V (3 x 1.5 mm²) fused with up to 6 A per outlet for external 230 V consumers.</p> |
| Connections from outside | <p>Cable gland incoming and outgoing for powerIO®-Line: M25</p> <p>2 x cable gland for 230V consumers: M20</p> <p>Port 1-4: Up to 4 RS485 Modbus RTU devices per port can be connected via the 4 x M12 5-pin A-coded connectors. At the same time they are supplied with 24V DC voltage. Pin assignment can be seen under "Electrical Installation".</p> |

Port 5: This can be extended via pluggable additional boards. Further protocols can be connected via this port and classic digital and analog inputs and outputs can be connected.

Port 6: M12 4-pin A-coded. Here the powerIO®-Bluetooth Dongle can be connected to the powerIO®-Box for configuration. This enables the commissioning of sensors and actuators via the powerIO®-App.

Communication

Each **powerIO®**-Box is assigned an individual IP address using the powerIO® App/Web interface or DIP switches. Each connected Modbus RTU sensor/actuator transmits its data and is converted by the powerIO®-Box to Modbus TCP protocol. This means that any PLC/DDC/GLT controller that has implemented the Modbus TCP protocol can be used to control the sensors and actuators.

Additional Modbus registers of the powerIO® box (status, 24V current measurement ...) can be called up. These Modbus registers are documented in the additional documentation. The serial slave address corresponds to the NodeID in the Modbus TCP query! Never assign the same slave address to each **powerIO®**-Box! Otherwise there will be conflicts in the TCP query. Furthermore the NodeID addresses 240 to 247 are reserved for the **powerIO®**-Box and are not allowed to be assigned serially.

Configuration

With the help of the **powerIO®**-App and the **powerIO®**-Bluetooth Dongle the following settings can be made on the **powerIO®**-Box:

- IP settings, Box Name
- Baud rate, communication parameters per RS485 COM port
- Testing the Modbus devices of common manufacturers through many device templates, which can also be created by yourself

In addition, the web interface of the **powerIO®**-Box can be called up via the IP address. The same settings as in the **powerIO®**-App are available via the web interface. Additionally firmware updates can be installed.

The default IP address at delivery is: DHCP

Call of the web interface: for example <http://192.168.60.250/>

Default logins for the web interface:

User: **powerio**

Password: **powerioT1**

Anwendungsbeispiel



powerIO®-Line
 All you need is our Hybrid-Cable for data transmission (Ethernet TCP/IP, 100 Mbit/s) and power (230V).

Free choice of control system
 The powerIO®-System is compatible with any ethernet-enabled PLC*, DDC* or BMS*!



powerIO®-Box
 The decentralized automation box distributes power and data. Depending on requirements, several powerIO®-Boxes can be connected to the powerIO®-Line. Serial protocols are converted to TCP/IP fully automatically – this offers enormous advantages in terms of speed and operational safety.

powerIO®-Start Unit
 This start coupling unit is used in the control cabinet and transfers data to separate powerIO®-Lines.

Control cabinet
 The powerIO®-System enables an extremely reduced switch cabinet construction. On the one hand reducing the power electronics (230/24V) consumers can be connected via the boxes). On the other hand the communicative sensor and actuator technology saves a lot of input and output modules – and thus also many cables.



Control according to IEC 61131-3
 Optionally, you can turn any powerIO®-Box into a CODESYS® PLC control. As room controller or the first box as central controller for your powerIO®-Line. For all Codesys based controllers, detailed libraries for communicative sensors and actuators as well as for HVAC* applications are available as download.



Accessories

| | Description | Typ |
|--------------|---|---------|
| Installation | powerIO®-Line Hybrid cable 3 x 4.0 mm ² / 2 x 2 x 0.34 mm ² , shielded  | T1.L100 |

powerIO® installation plate Aluminum Wall Mount T1.Z119

M12 connection accessories T1.ZXXX



Service Tools **powerIO®-Bluetooth Dongle** T1.D100
M12 Bluetooth configuration dongle



powerIO®-App
for Android / iOS

download the powerIO®-App

www.powerio.com/app

Get it on
Google Play

Download on the
App Store

Extensions **powerIO®- extension boards** T1.C100-XX
for other bus protocols or I/Os

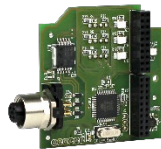

Electrical Installation

Notes



- The relevant RS485 guidelines must be followed when wiring the lines for BACnet MS/TP / Modbus RTU.
- Power supply and communication of BACnet / Modbus are not galvanically isolated. Connect the ground signals of the devices with each other.

Connection diagram upper area - Inside: Performance and communication

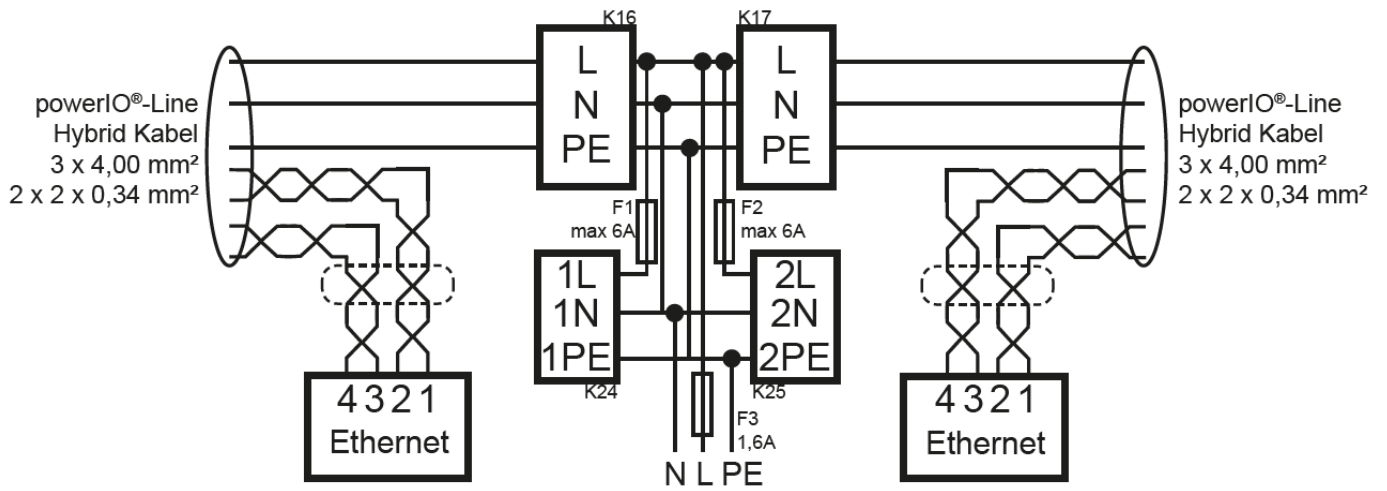

Cable colors Ethernet:

- 1 = WH (white)
- 2 = YE (yellow)
- 3 = WH (white)
- 4 = GN (green)

Cable color performance:

- L = BR (brown)
- N = BL (blue)
- PE = GN/YE (green/yellow)

Connection diagram lower area – outside:

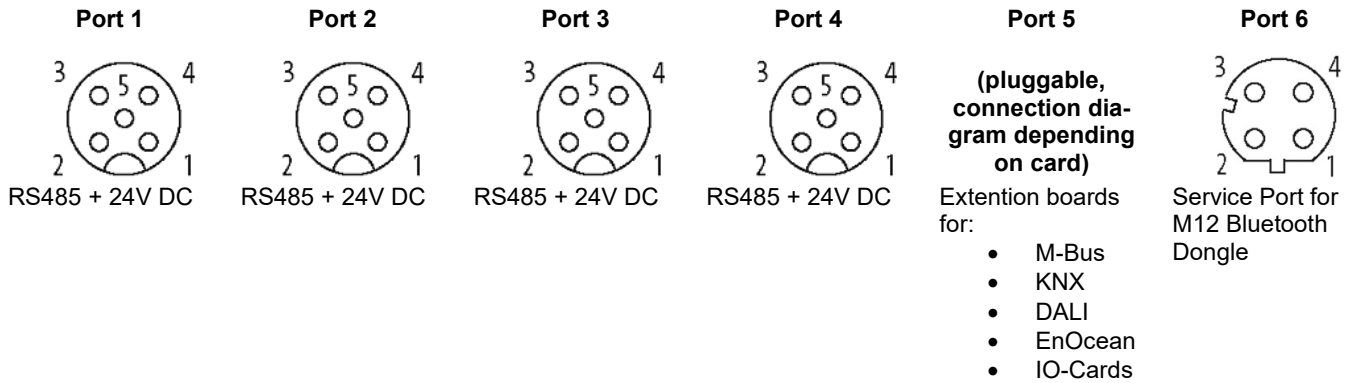

Assignment and cable colors for M12 accessories T1.Zxxx

Port 1-4, M12 A-coded 5-pin:

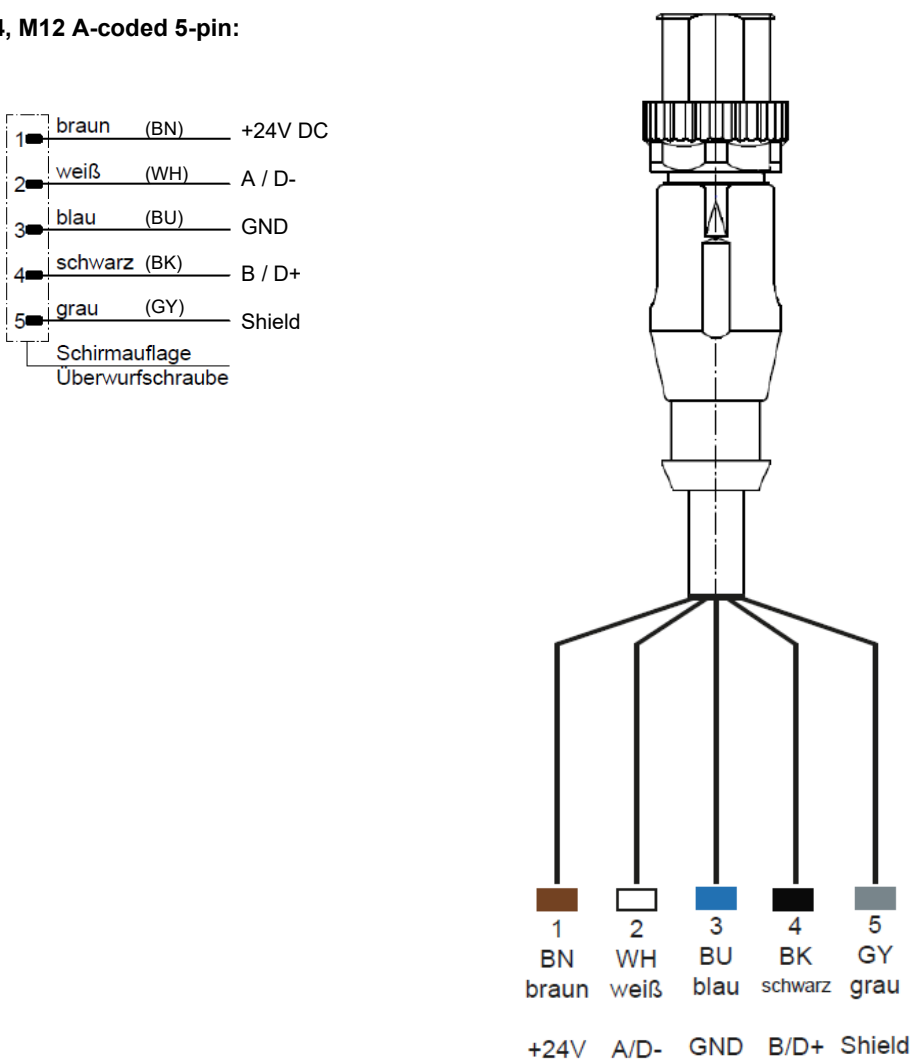

Please refer to the respective documentation for connection diagrams for expansion boards (port 5).



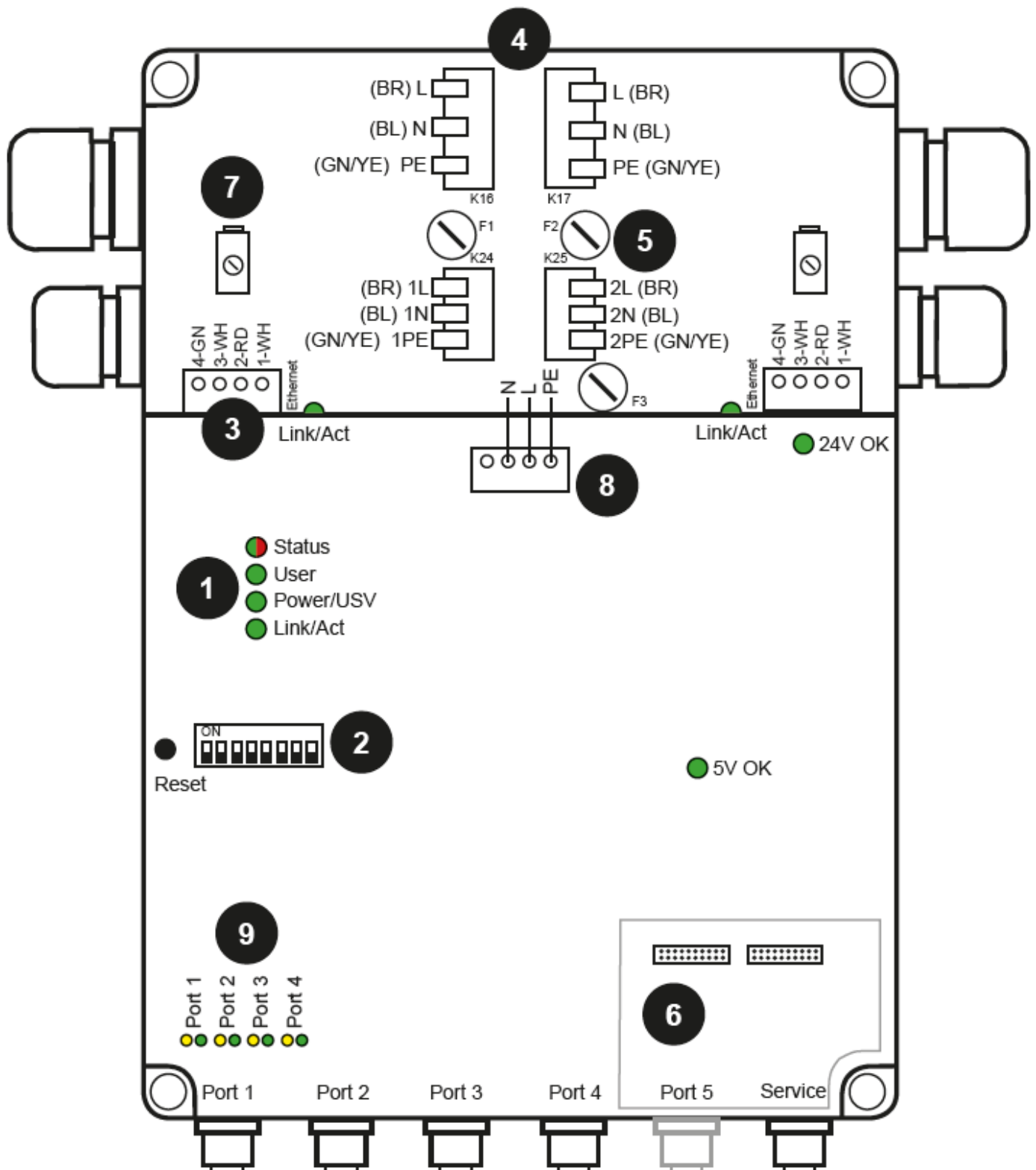

Port 1 to port 4 corresponds to the standard M12 A-coded.

Port 6 corresponds to the standard M12 D-coded.

Display, operating elements and terminals



Display, operating elements and terminals

| | |
|----------|---|
| 1 | <p>Status LEDs</p> <p>Status flashing green: everything ok permanent red: collective fault</p> <p>User green: free use</p> <p>Power/USV permanent green: voltage ok flashes green: UPS charging/discharging</p> <p>Ethernet permanent green: Link flashes green: Communication (Act)</p> <p>24V OK permanent green: 24V voltage ok off: no 24V voltage available</p> <p>5V OK permanent green: 5V voltage OK off: no 5V voltage available</p> |
| 2 | <p>DIP IP addressing</p> <p> All ON: IP address set to DHCP. (default)</p> <p> All OFF: IP address set to configuration via App/Web</p> <p> Manual IP address of the last IP location: 192.168.60.1 (DIP1 ON) ...</p> <p> 192.168.60.3 (DIP1 & 3 ON) ...</p> <p> 192.168.60.254 (DIP2-8 ON) max address</p> <p>Video: https://youtu.be/M9WfinYbEY8</p> |
| 3 | <p>Pluggable terminal block</p> <p>Ethernet Connection of the 4 wires of the powerIO®-Line for Ethernet TCP/IP communication (2x, right/left, coming/going). Conductors do not have to be stripped, insulation displacement connector. The two connectors can also be plugged into each other, thus bridging a powerIO®-Box. Adapter necessary.</p> <p>LED green = Link flashes green: Communication (act)</p> |
| 4 | <p>Fixed connection terminal K16/K17</p> <p>Performance Connection of the 3 x 4.0 mm² power wires of the powerIO®-Line (2x, coming/going).</p> |
| 5 | <p>Outlet 230V AC consumer with fuse</p> <p>Terminal Connection of 230V consumers (2x, outlet left/right) K24/25 maximum cross-section 2.5 mm² Backup 2x 230V, up to 6A fuse for voltage outputs. Fuse left/right for outgoing F1/2 left/right. Delivery with 2A fuse.</p> |
| 6 | <p>Optional extension</p> <p>Slot Optional slot for powerIO®-Expansion boards. Touch protection and M12 provision must be broken out. Observe the documentation of the respective board!</p> |

| | |
|-----------------|---|
| <p>7</p> | <p>Shield clamp</p> <p>left/right The two separately shielded wire pairs of the powerIO® line are placed underneath and slightly tightened. Enables fast and efficient shielding of the data line. Put the shield back on the coat and tighten it slightly with the shield clamp.</p> |
| <p>8</p> | <p>Pluggable terminal block</p> <p>Communication board This terminal supplies the communication board as well as the 24V and 5V power supply unit with 230V. The communication board can be disconnected for VDE measurements..</p> |
| <p>9</p> | <p>Port 1 to 4 communication - 2 LEDs per separate COM port</p> <p>LED orange flashes: TX - Data is sent serially on this port</p> <p>LED green flashes: RX - Data is received serially on this port.</p> |

Dimensions [mm]

View from above

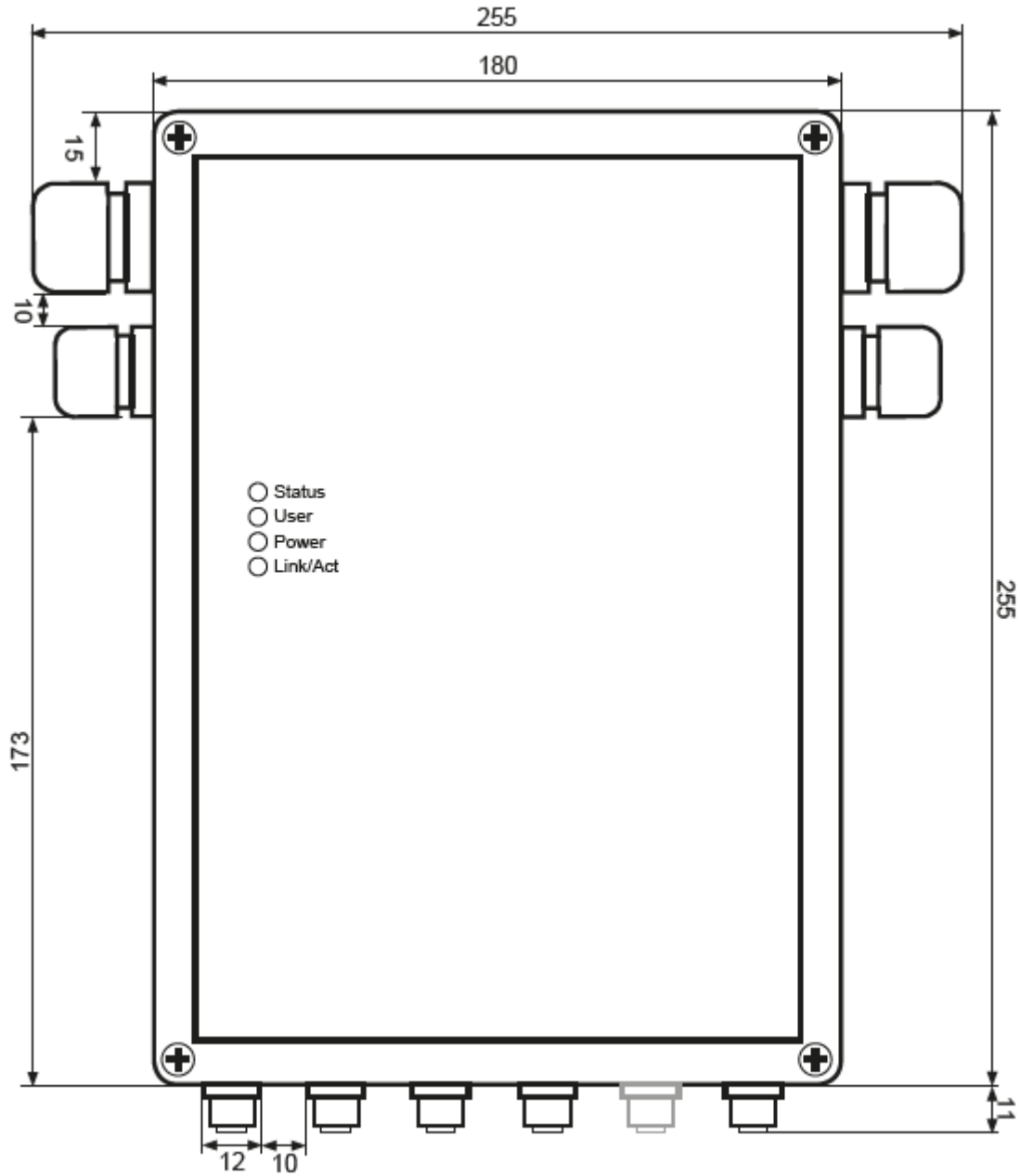

View from the side



Further documentation

download area

Software updates, further documentation:

<https://www.powerio.com/de/produkte/t1.b100-powerio-box>**Youtube Video Channel**

Videos on installation, commissioning:

<https://www.youtube.com/channel/UCe-ukckqz3BeRexlvQPK-qg>

Further notes



The device contains electrical and electronic components and must not be disposed of as household waste. The local and currently valid legislation must be observed.

Copyright

Copyright © 2020 powerIO® GmbH. All rights reserved. No part of this manual may be reproduced, transmitted, transcribed, stored in a retrieval system, or translated into any language or computer language without the express written permission of the author.

This applies to any form and any means, whether electronic, mechanical, magnetic, optical, manual or any other way.

Modbus is a registered trademark of Schneider Electric, licensed to the Modbus Organization

Raspberry Pi is a trademark of the Raspberry Pi Foundation

ARM is registered trademark and ARM Limited Linux is a registered trademark of Linus Torvalds

All other brand names or product names are the property of their respective holders

Supportsupport@powerio.com**powerIO GmbH**

Building Automation

Eberhardstraße 65

70173 Stuttgart

Tel +49 (0)711 99887200

E-Mail: office@powerio.comwww.powerio.com